

NOTES:

1. CONNECTIVITY: REFER TO WIRING DIAGRAM 9-8100-MXXXP0.VSD
2. ALL SCREWS TO BE TORQUED TO: 8-12 IN-LB (0.9-1.4 Nm)
3. USE TIE WRAPS (140-0210) TO BUNDLE CABLES AS NEEDED
4. APPLY PRESSURE FOR AT LEAST 5 SEC. FOR ADHESIVE TO ADHERE TO PLASTIC SHROUD WHEN HR BOARD (715-3864) IS MOUNTED
5. COLOR: -XX COLOR DESIGNATOR AS SPECIFIED IN SOP 620-8222

REVISION HISTORY

REV	DATE	DESCRIPTION	ECO	BY
A	12/3/2013	PRODUCTION RELEASE	14443	MMG
B	4/25/2014	REMOVE: 715-3806 (1); ADD 240-6846 (1), 715-4012 (1)	14630	MMG

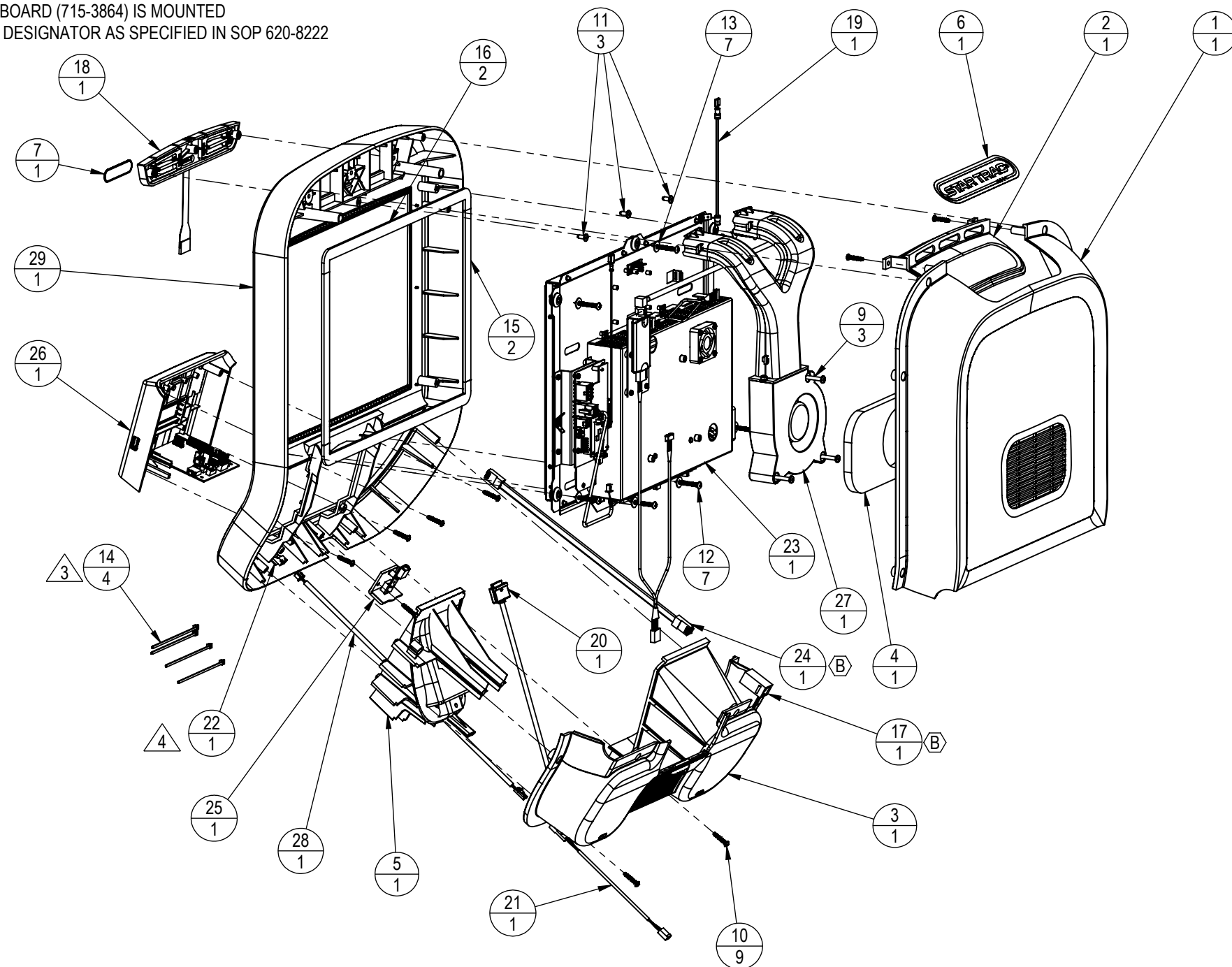

ITEM NO.	PART NUMBER	DESCRIPTION	QTY.
1	020-7053	HOUSING, BACK, TOP, BCS	1
2	020-7058	HOUSING, TV CAP, BLANK, BCS	1
3	020-7078	ASSY, BOTTOM, CUP HLDR, BTS	1
4	020-7284	GASKET, BLOWER, E-BTSe	1
5	020-7289	POCKET, IPOD HOLDER, E-SERIES	1
6	050-2041	LOGO, STAR TRAC, 6.425X1.523	1
7	050-2114	LOGO, ST BADGE, 2.447" X .580"	1
8	050-2188	LABEL, WORDMARK, Nike + iPod	1
9	110-3170	SCREW, M4x35, PHM, PH, CS, ZI	3
10	110-3402	SCREW, #8-18, 3/4", HI-LOW, PHT, PH, CS, BO	9
11	110-3404	SCREW, M4x0.7x10L, PHT, PH, CS, BO	3
12	110-3460	SCREW, #8, 1.25", PHTF, PH, SS, BO	7
13	120-3307	WASHER, M4, 4.3mm I.D. X 12mm O.D., ISO 7089	7
14	140-0210	TIE STRAP, 3.5"	4
15	140-3467	FOAM, ADHESIVE, 202.5mm x 1/8" THICK	2
16	140-3468	FOAM, ADHESIVE, 308.25mm 1/8" THICK	2
17	240-6846	CONNECTOR, 8 PIN, INLINE	1
18	715-3651	ASSY, AIR VENT, BCS	1
19	715-3676	HARNESS, DISPLAY GND STRAP, PRO	1
20	715-3774	HARNESS, IPOD INTERFACE	1
21	715-3805	CABLE, WHR EXTENSION	1
22	715-3864	ASSY, WIRELESS HR, POLAR, 92cm L.R.	1
23	715-3964	ASSY, TOUCH SC W/CHR, NTSC, ATSC, QAM	1
24	715-4012	ASSY, HARNESS, CSAFE, ECOFIT	1
25	718-5098	ASSY, HEADPHONE JACK, BCS	1
26	718-5163	ASSY, CENTER CONSOLE, E-BTSe	1
27	718-5170	ASSY, BLOWER, E-BTSe	1
28	718-5196	ASSY, CABLE, WIRELESS HR	1
29	718-5515-XX	HOUSING, COVER, BTSe, LCD, FNT	1

DOCUMENT STATUS:

NOTICE OF PROPRIETARY INFORMATION
THIS DOCUMENT SHALL NOT BE REPRODUCED NOR SHALL THE INFORMATION CONTAINED HEREIN BE USED BY OR DISCLOSED TO OTHER EXCEPT AS EXPRESSLY AUTHORIZED BY CORE HEALTH & FITNESS, LLC.

CLASS OF WORK	UNLESS OTHERWISE SPECIFIED DIMS ARE IN mm. TOLERANCES FOR MEASURE OF LENGTH ARE:							ANGLES = ±2°
	0.5 to 3	>3 to 6	>6 to 30	>30 to 120	>120 to 400	>400 to 1000	>1000 to 2000	
FINE	±0.05	±0.05	±0.1	±0.15	±0.2	±0.3	±0.5	----
MEDIUM	±0.1	±0.1	±0.2	±0.3	±0.5	±0.8	±1.2	±2
COARSE	±0.2	±0.3	±0.5	±0.8	±1.2	±2	±3	±4
VERY COARSE	----	±0.5	±1	±1.5	±2.5	±4	±6	±8

MATERIAL SEE BOM
FINISH PER SOP 620-7868
VENDOR: N/A P/N: N/A

THIRD ANGLE PROJECTION		
DRAWN	INITIAL	DATE
CHECKED		
APPROVED		
	U.O.M.	MM

CORE HEALTH & FITNESS, LLC
4400 NE 77th Ave., Suite 300
Vancouver, WA 98662
CORE PART NO: **721-1183-XX** REV: **B**
TITLE: **ASSY, GEN 3 DISPLY, E-BTSe, NTSC**
SCALE: 1:6 SHEET 1 OF 2 SHEET SIZE: B

- NOTES:
 6. USE NON-MARKING, LOW TACK TAPE TO HOLD TOGETHER THE COMPLETE ASSEMBLY
 7. CLEAN AREA WITH ISOPROPYL ALCOHOL PRIOR TO APPLICATION OF TAPE AND STICKER

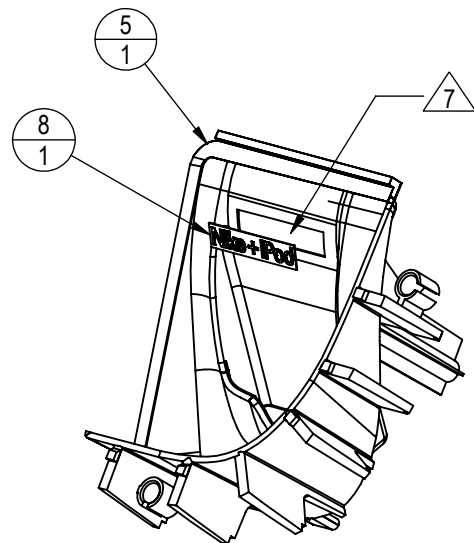

**FOAM GASKETS
 ASSEMBLY INSTRUCTIONS**

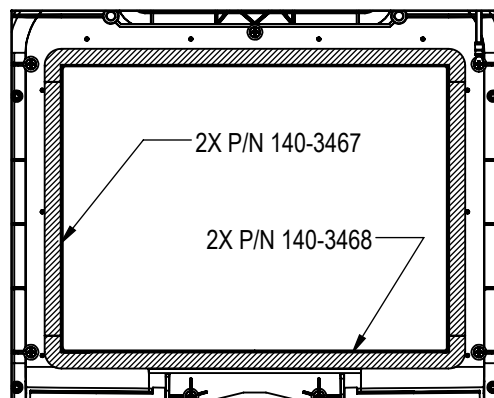

STEP 1:
 PLACE FOAM IN SHOWN LOCATION (NO GAPS BETWEEN VERTICAL AND HORIZONTAL GASKETS)

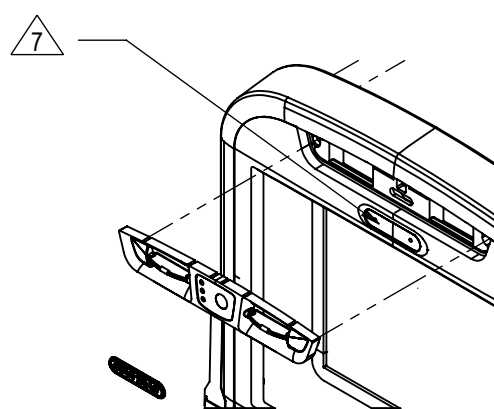
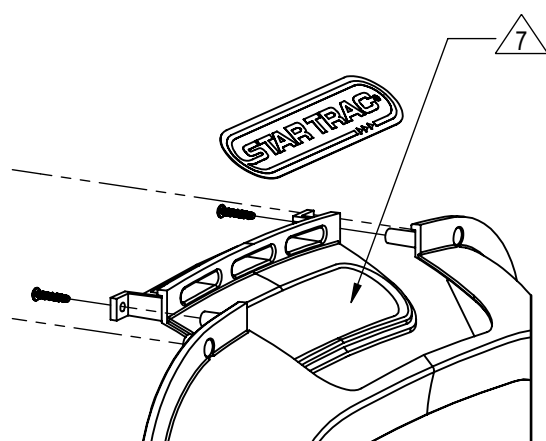
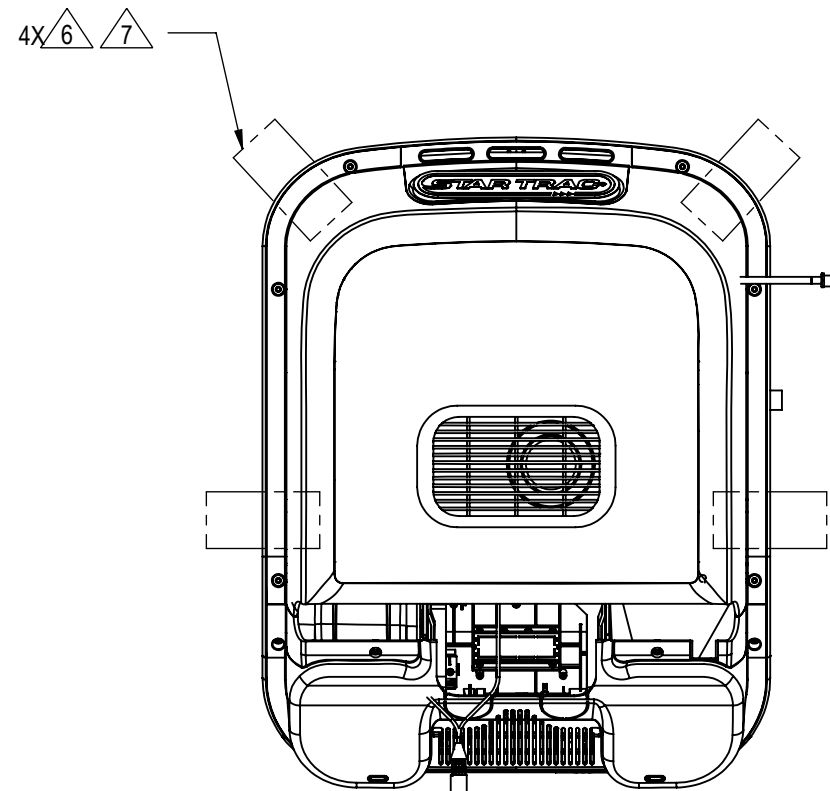

CORE HEALTH & FITNESS, LLC 4400 NE 77th Ave., Suite 300 Vancouver, WA 98662		
CORE PART NO	721-1183-XX	REV B
TITLE ASSY, GEN 3 DISPLY, E-BTSe, NTSC		
SCALE: 1:6	SHEET 2 OF 2	SHEET SIZE: B